

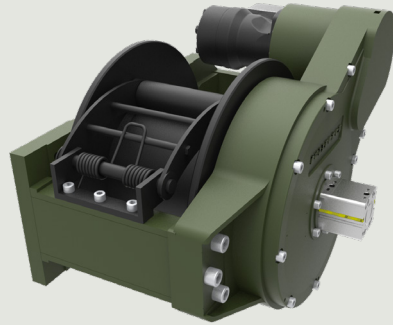

Description

Towing and recovery winch for commercial and service vehicles with a vertically positioned motor. This model has a rigid planetary gear, disc brake system and ductile iron body ready for challenging tasks. Different configurations are available upon request. Fully compliant with **EN 14492**. Additional equipment and accessories are available as well.



Specifications

| | |
|--------------------------|---------------------------------|
| Maximum Pulling Capacity | : 12000 kg / 26455 lbs |
| Maximum Rope Length | : 43 m / 141.1 ft |
| Recommended Wire Rope | : Ø16 mm / Ø5/8" |
| Hydraulic Motor | : 200 cc / 12.2 in ³ |
| Maximum Pump Flow Rate | : 60 l/min / 15.85 gal/min |
| Max Working Pressure | : 175 bar / 2538 psi |
| Weight | : 210 kg / 463 lbs |

Additional Equipment

Standard package:

- Rope
- Roller fairlead
- Pressure roller
- Pneumatic freespool
- Hydraulic inlet G 1/2"

Optional:

- Radio control system
- ECU & IQAN equipment
- M16 mounting bolts
- Hydraulic control valve with manual lever

Line Pull and Line Speed Performance

| Winding layer | Pulling capacity (kg / lbs) | Rope speed (m/min - ft/min) | Rope length (m/ft) |
|---------------|-----------------------------|-----------------------------|--------------------|
| 1 | 12000 / 26455 | 5.8 / 19 | 8.8 / 28.9 |
| 2 | 10451 / 23041 | 6.6 / 21.9 | 10.1 / 33.2 |
| 3 | 9257 / 20408 | 7.5 / 24.7 | 11.4 / 37.5 |
| 4 | 8307 / 18315 | 8.4 / 27.5 | 12.7 / 41.7 |



These winches should not be used for lifting and there should be at least 5 wraps of wire rope on the drum. The data shown are for maximum pressure and maximum flow and should be used as a reference only.

PULLFORCE reserves the right to change the specified data without prior notice.

Dimensions

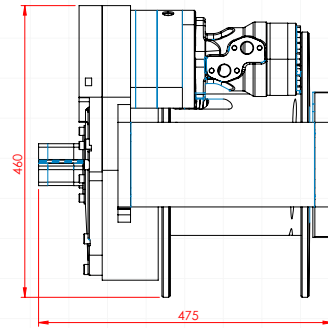
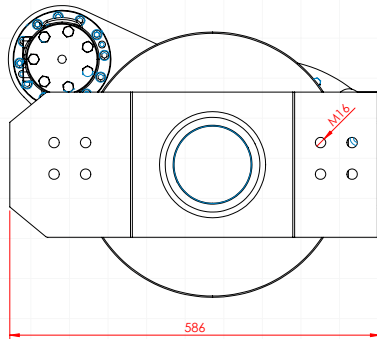

Hydraulic Circuit

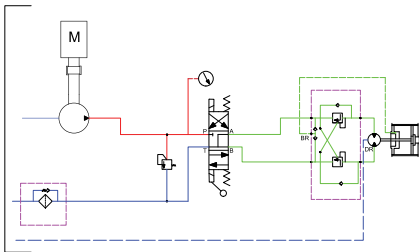

Hydraulic Performance

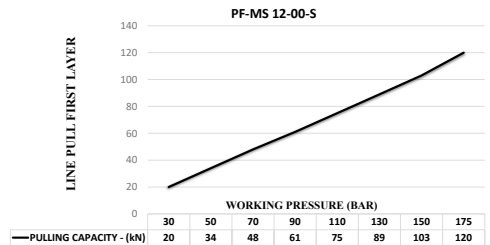

Features

- Gear reduction : 41.25:1
- Gear type : Two stage planetary
- Winch construction : Ductile iron body reinforced with heat-treatment
- Braking : Negative hydraulic disc brake system
- Drum rotation : Clockwise, or counter clockwise rotation as required
- Roller guides : Commercial type with large diameter rollers and grease ways
- Free spooling : Standard pneumatic freespool.
- Control valve : The direction control valves to be used must be A, B, and T. The A and B lines must be open to the T (Tank) line.

Application Areas



Towing and Recovery Vehicles



Heavy Tow Trucks



Agricultural and Forestry Vehicles



Military Vehicles



Trailers



Each new winch is guaranteed against defects in workmanship and material defects for a period of 24 months from date of purchase. Wire ropes are not included under warranty.